

THIS DRAWING IS UNPUBLISHED. RELEASED FOR PUBLICATION  
 © COPYRIGHT BY TYCO ELECTRONICS CORPORATION. ALL RIGHTS RESERVED.

LOC	DIST	REVISIONS			
P	LTR	DESCRIPTION	DATE	DWN	APVD
GP	00	B	REVISED PER ECO-08-008760	30JUL2008	ZMRCWR

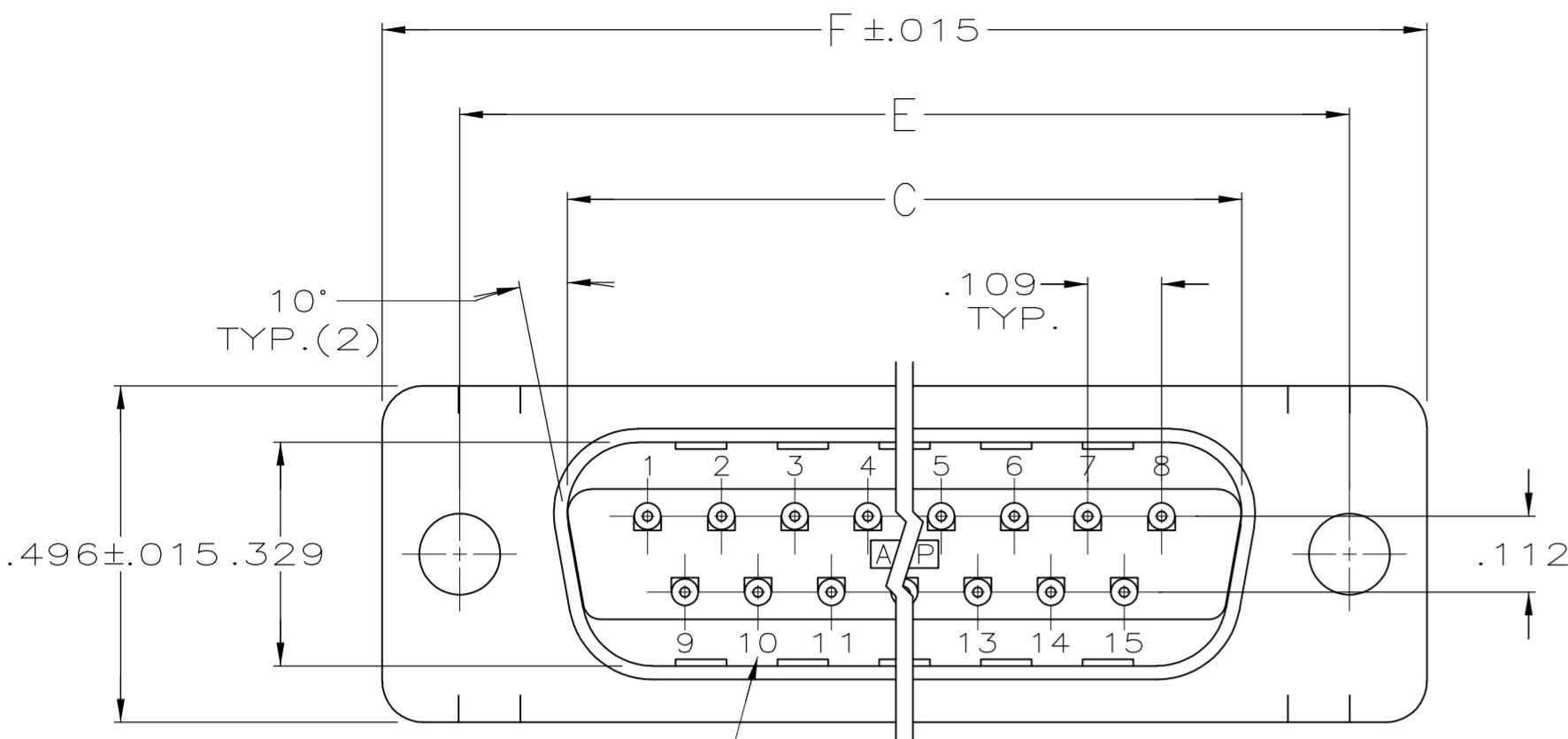

RAISED CAVITY IDENTIFICATION  
(15 POSITION SHOWN)

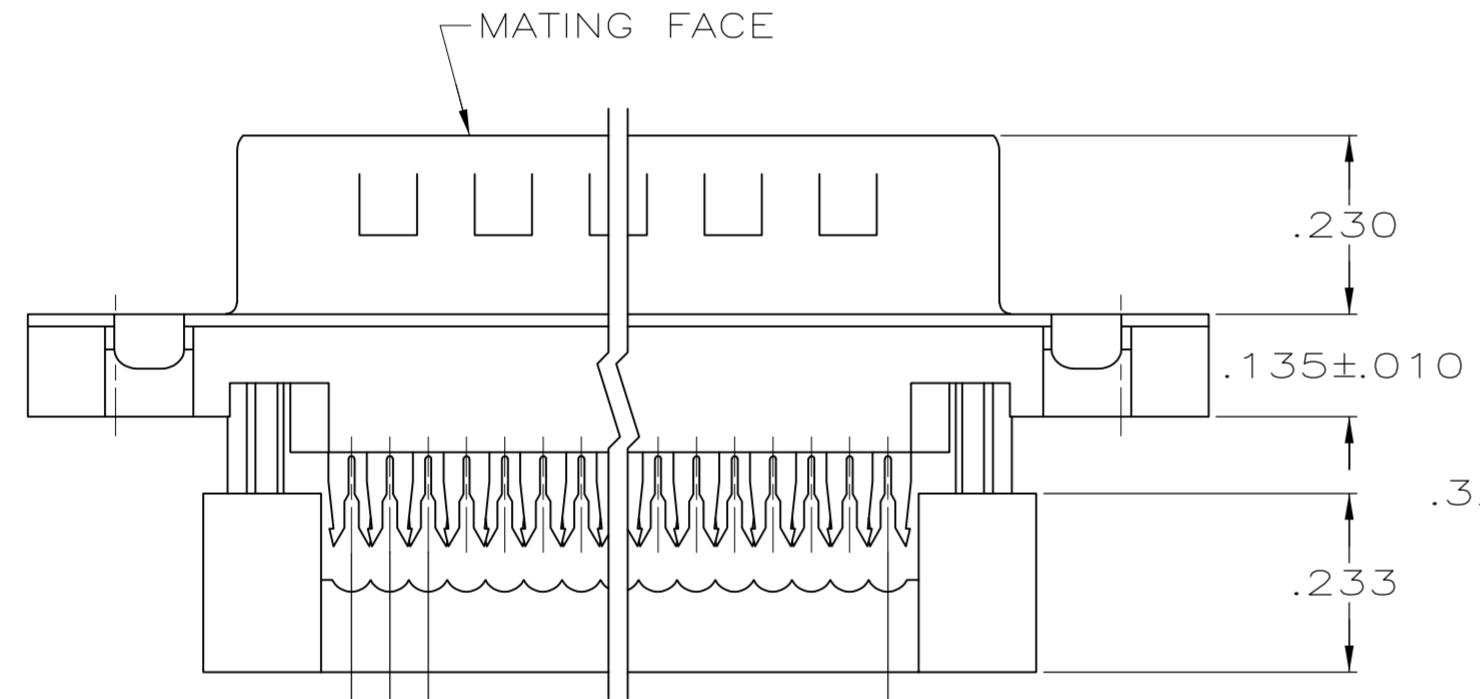

.050 REF.  
 .100 REF.  
 A SPACES AT .050 = B

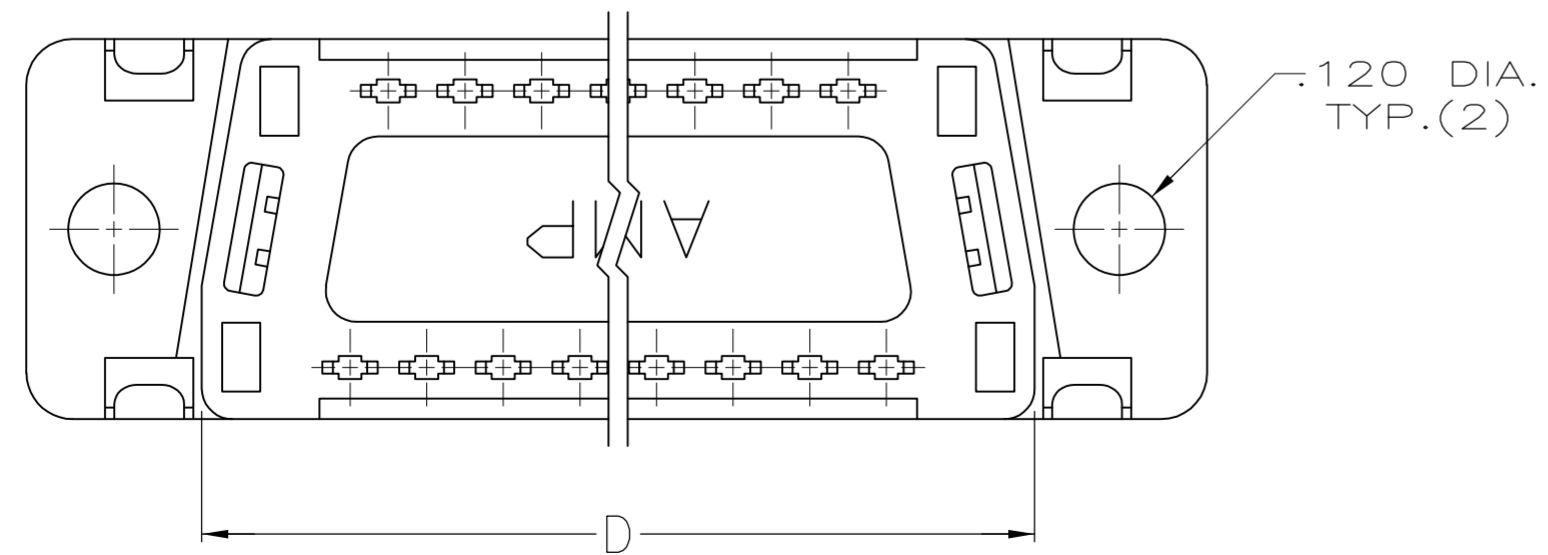
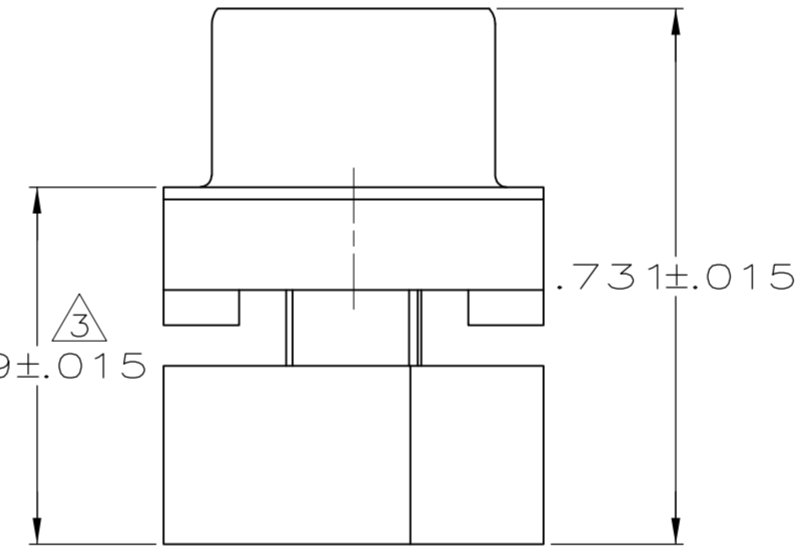

- CONNECTORS COMPLY WITH AMP SPEC. 108-40,012 AND MATE WITH ANY SAME NUMBER POSITION RECEPTACLE CONNECTOR IN AMPLIMITE SERIES.
- CONNECTOR DESIGNED FOR 28 AND 26 AWG STRANDED AND SOLID CONDUCTOR RIBBON CABLE ON .050  $\phi$ .
- DIMENSION APPLIES TO TERMINATED CONNECTOR.
- MOLDED PARTS: FLAME RETARDANT 94V-0 RATED THERMOPLASTIC; COLOR: BLACK.
- SHELL: STEEL PER QQ-S-698.
- CONTACTS: PHOS. BRONZE PER QQ-B-750.
- GOLD PLATING PER MIL-G-45204, TIN PLATING PER MIL-T-10727 NICKEL PLATING PER QQ-N-290.
- SHELL: BRIGHT TIN PLATED.
- CONTACTS:  
 .000030 GOLD ON MATING END, .000100-.000200 MATTE TIN ON TERMINATION END, ALL OVER .000050 NICKEL ON ENTIRE CONTACT.  
 OR  
 GOLD FLASH OVER PALLADIUM-NICKEL ON MATING END, .000030 MIN TOTAL, .000100-.000200 MATTE TIN ON TERMINATION END, ALL OVER .000050 NICKEL ON ENTIRE CONTACT.

1.216	.984	.759	.666	.400	8	9	1658613-4
1.541	1.312	1.087	.994	.700	14	15	1658613-3
2.090	1.852	1.623	1.534	1.200	24	25	1658613-2
2.732	2.500	2.275	2.183	1.800	36	37	1658613-1
F	E	D	C	B	A	NO.OF POS.	PART NUMBER

THIS DRAWING IS A CONTROLLED DOCUMENT.

DWN	L. BAUM	6/13/03	Tyco Electronics Corporation Harrisburg, PA 17105-3608	
CHK	C. ROHDE	6/13/03		
APVD	M. WALMSLEY	6/13/03		
PRODUCT SPEC				
NAME	PLUG ASSEMBLY, FRONT METAL SHELL, LEAD-FREE, AMPLIMITE HDF			
APPLICATION SPEC	SIZE	CAGE CODE	DRAWING NO	RESTRICTED TO
	A2	00779	C=1658613	
MATERIAL	FINISH	WEIGHT	SCALE	SHEET
			4:1	1 of 1
CUSTOMER DRAWING		REV	B	